

### FOR DOORS WITH 1-1/4" HOLE

A backset of 2-7/16" from jamb to center or 2-3/4" from door edge to center is acceptable. Strike sham shim can be used or not used to make adjustments to the roller strikes projection to compensate for doors with different backsets.

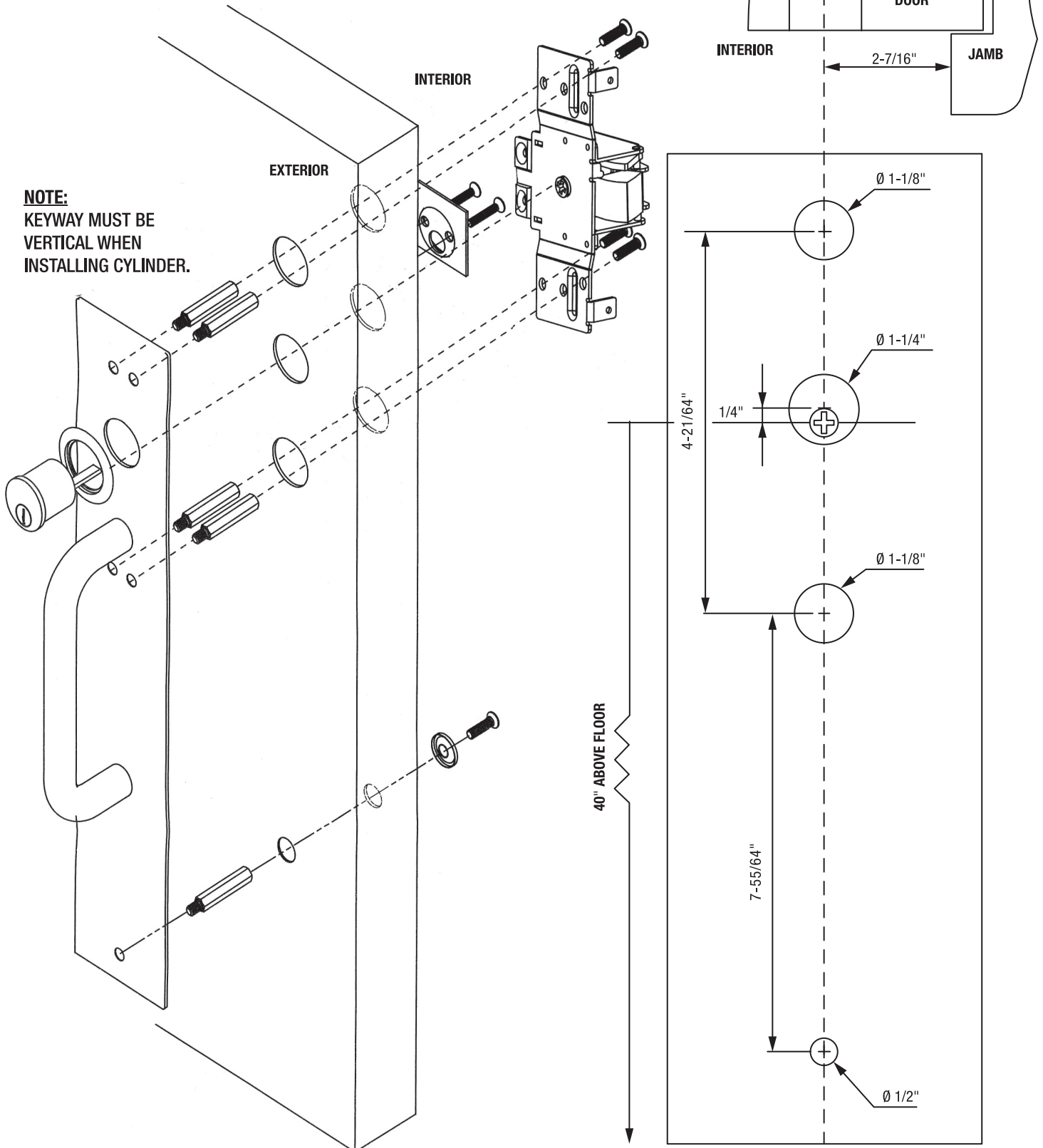

### FOR DOORS WITH 2-1/8" HOLE / 161 PREP REQUIRING CYLINDER SLEEVE

A backset of 2-7/16" from jamb to center or 2-3/4" from door edge to center is acceptable. Strike sham shim can be used or not used to make adjustments to the roller strikes projection to compensate for doors with different backsets.

